

# HMG Fuse Holder

Fuse Holders

## Automotive Bolt-In Fuse Holder for the AMG Fuse



The HMG fuse holder accepts industry standard AMG fuses for primary fusing applications. The narrow rugged body makes it ideal for demanding environments such as 'under the hood' locations in construction, agriculture, heavy trucking and specialty vehicle applications.

### Specifications

**Rating:** For use with AMG fuses from 100-300A. (see pg 75 for AMG fuse)  
**Temperature Rating:** -40°F (-40°C) to 260°F (125°C)  
**Materials:** Black thermoplastic with zinc-plated steel studs  
**Termination:** M8 or 5/16-18 threaded studs and hex nuts for fuse mounting. Wire sizes: #2-8 AWG  
**Torque Rating:** 150 in-lbs (17N•m) max  
**Mounting Torque Rating:** Optional mounting hole patterns, 44 in-lbs (5N•m) max

### Features

- Side-stackable
- Bottom side insulated from mounting panel
- Splash resistant cover

**Dimensions - mm(in)** (Dims.shown are for reference only. Consult factory for latest prints)

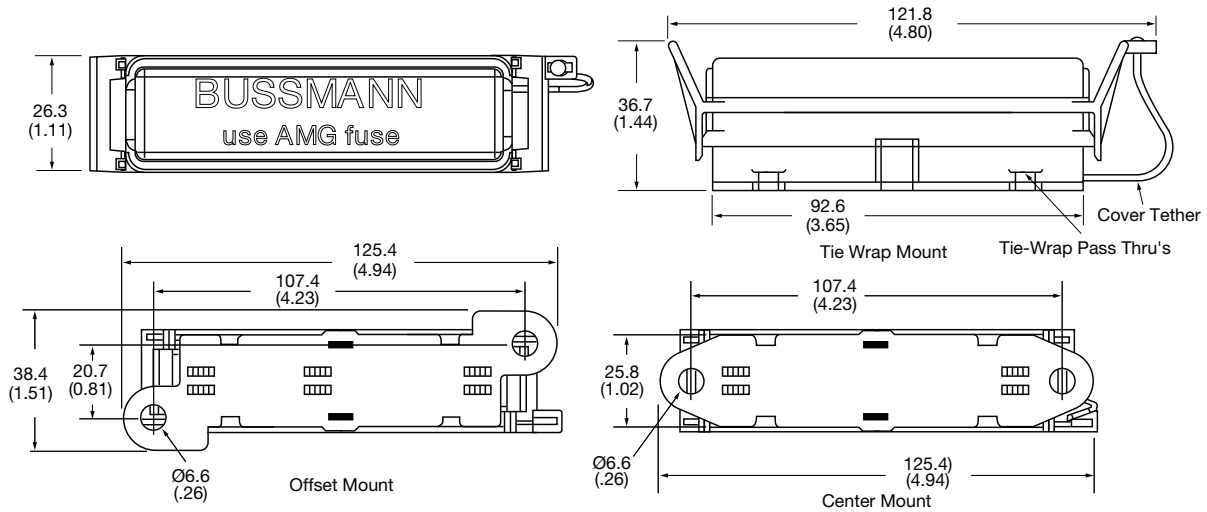

### Part Numbering System

Series	Base	Hardware	Style
HMG	—	□	□
	1 - Tie wrap mount 2 - Offset mounted 3 - Center mounted*	1 - 5/16-18 Studs w/nuts installed 2 - 5/16-18 Studs w/nuts bulk 3 - 5/16-18 Studs w/o nuts 4 - M8 x 1.25 studs w/nuts installed 5 - M8 x 1.25 studs w/nuts bulk 6 - M8 x 1.25 studs w/o nuts	0 - No cover 1 - Cover installed 2 - Cover bulk

\*Consult factory for availability.